

Hella Product Summary: Trucks

Top technology for demanding heavy-duty use

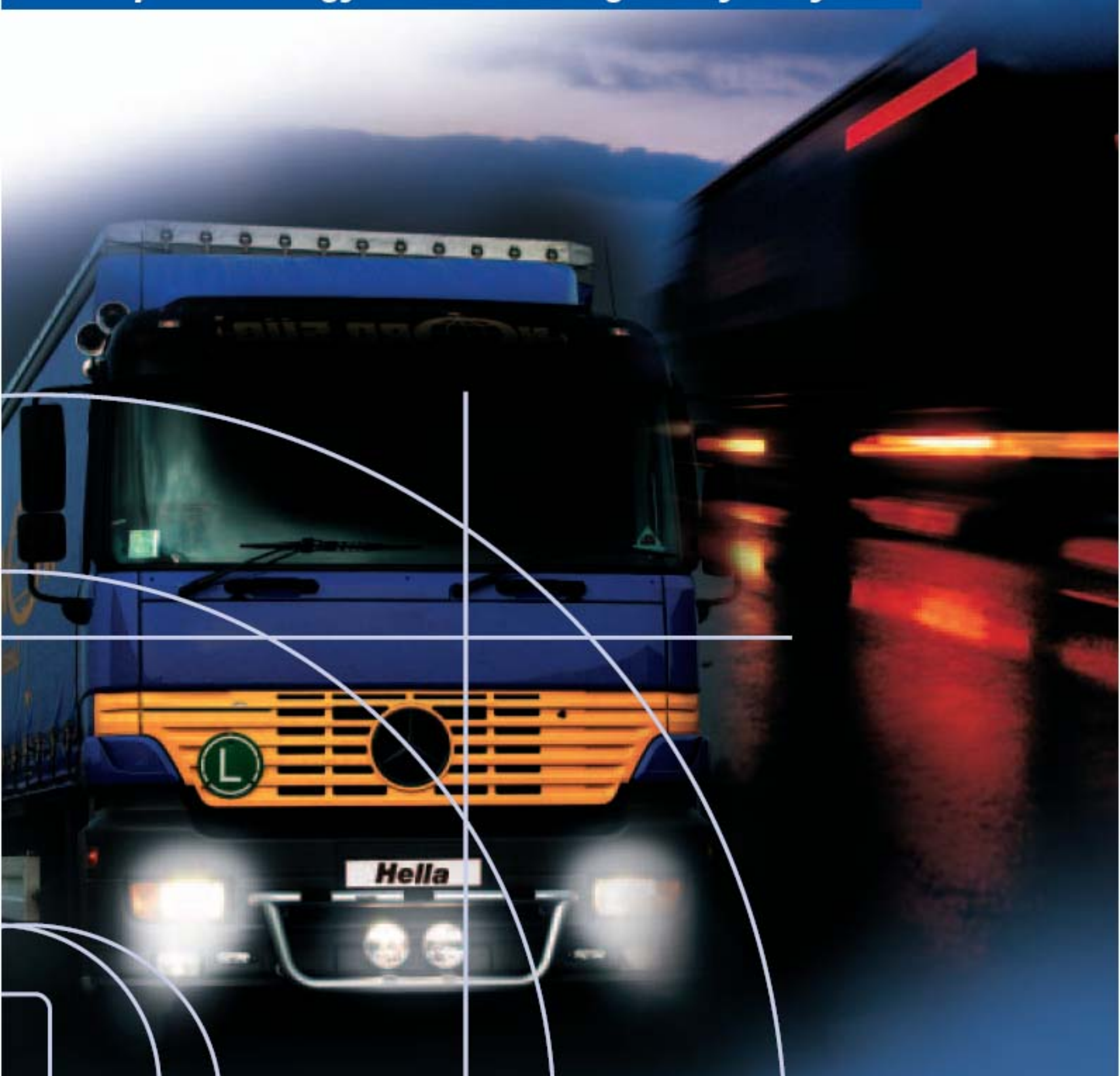

*Ideas today for
the cars of tomorrow*

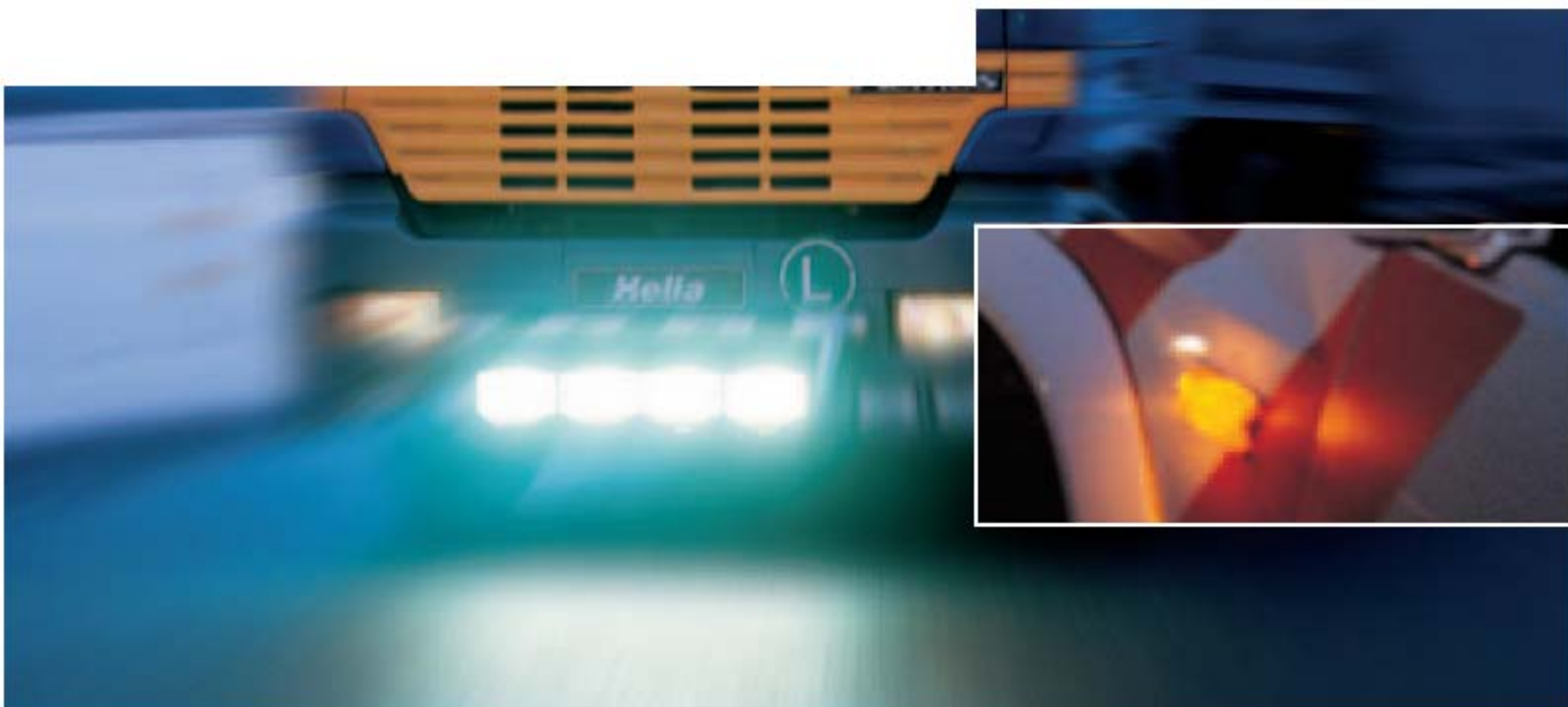

Introduction

For more than a 100 years now, Hella has been setting milestones for the future of motor vehicles – and Hella will continue to be one of the leading partners of the automobile industry around the world in future, too. Enormous innovative strength and a high level of creativity from the company's own research and development are integrated directly in production and sales – to benefit the customer. A successful process of short decision-making paths. Thus guaranteeing supplies of all the products in the Hella range to the aftermarket and workshops – in the fields of lighting, electrics and electronics as well as air conditioning.

In addition, Hella provides outstanding customer support in the form of powerful service packages for successful, booming business in the areas of sales support and technical service.

Here some of the excellent arguments:

- Wide range
- High market cover
- OEM quality
- Innovative technologies
- Trend-setting design
- High availability
- Convincing logistics

Trucks are in continual use and have to run safely – Hella is the competent partner for miles and miles – both by day and night. This brochure provides a summary of the current Hella range of products for trucks.

The complete range is documented in detail in the main Hella catalogues or in various special brochures.





Contents

Hella Technology

- | | |
|---|---|
| <p>4 See and be seen optimally – for trucks as important as brake force and torque.</p> <p>5 LED – exploit the technological lead</p> <p>6 Hella xenon light turns night into day</p> <p>7 DynaView® – curves are getting brighter</p> <p>8 Modern electric systems for trucks from Hella – a convincing range of products</p> <p>Hella Lighting for Trucks</p> <p>10 Hella auxiliary lamps – Profi-Line Xenon</p> <p>12 Hella auxiliary lamps – Profi-Line Halogen</p> <p>14 Hella auxiliary lamps – Profi-Line Blue</p> <p>15 Xenon conversion kits for Mercedes-Benz Actros and Scania BR 4</p> <p>16 Main headlamps for trucks</p> <p>18 Work lamps</p> | <p>20 Beacons and strobe-type beacons</p> <p>22 Optical warning systems</p> <p>23 Seven-chamber lamps</p> <p>25 Hella multiple function lamps</p> <p>27 Red position/clearance lamps</p> <p>28 White position and clearance lamps</p> <p>29 Side marker lamps</p> <p>30 Reflex reflectors</p> <p>31 Hella hazard warning lamps, warning triangle, reading lamps</p> <p>Hella Electrics for Trucks</p> <p>32 Starters and alternators for trucks</p> <p>33 Horns and fanfares</p> <p>34 Relays</p> <p>35 Flasher units</p> <p>36 Voltage reducers and load compensation devices</p> <p>37 Plugs and sockets</p> <p>38 Keeping an eye on safety – Hella mirrors for safe and comfortable manoeuvring</p> <p>39 Hella back-up alarm – acoustic signalling system in reverse gear</p> |
|---|---|





See and be seen optimally – for trucks as important as brake force and torque

Humans do not have naturally good night-time vision – which is why our eyes have to rely on additional light sources in the dark and in poor, diffuse visibility conditions.

This is particularly true, of course, for professional participation in road traffic – here, better road illumination and being seen more quickly often mean vital life-saving seconds of reaction time. Truckers cannot choose when and where they want to drive – country roads alternate with motorways, with a wide range of different weather conditions having to be coped with, too.

Just as important is the best possible visibility of the vehicle with semitrailer or trailer from the rear and from the sides. Hella all-round lighting means added safety in these areas as well.

All in all, Hella provides truckers and other road users with an extremely high degree of reliability and safety. By using state-of-the-art technologies such as xenon, LED and DynaView* – available from wholesalers,

More details about all these products are on the following pages.



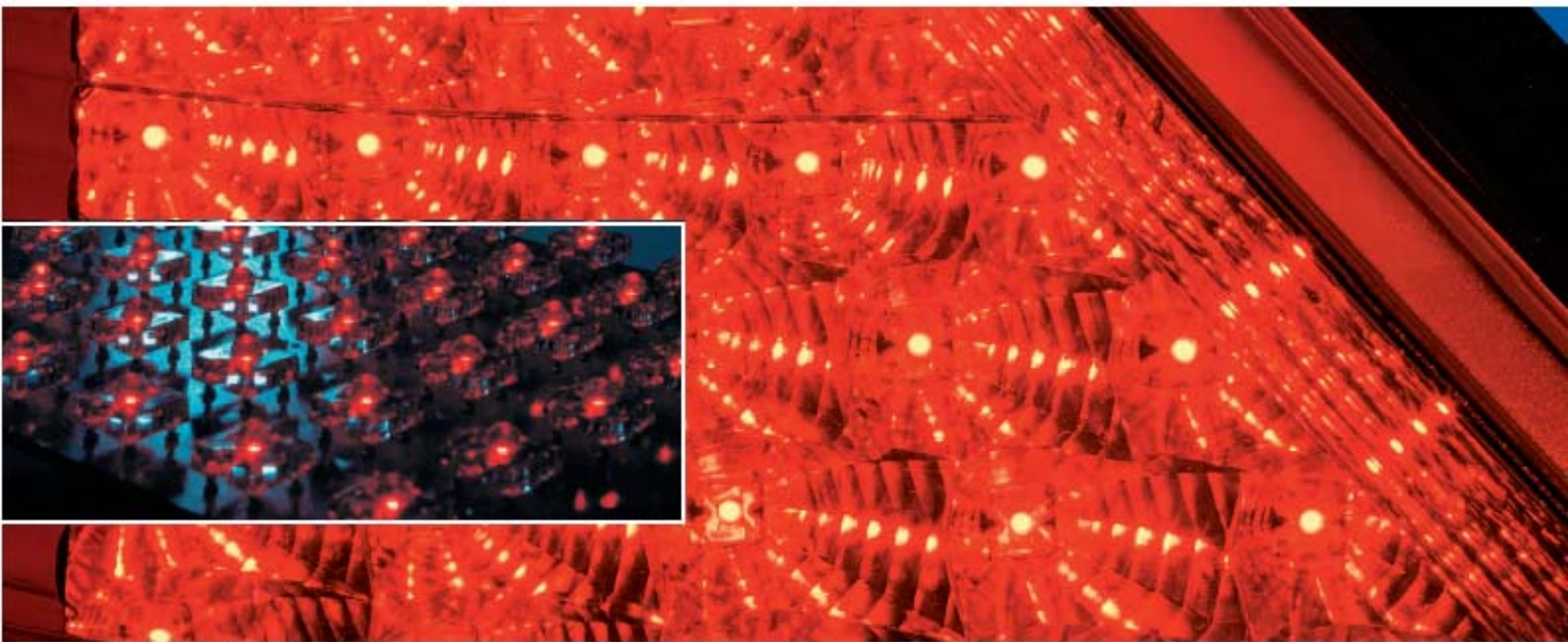

LED - exploit the technological lead

Operating safely plays a major role particularly for trucks which are on the road day and night. The new Hella lamps using LED technology pick up where other lighting concepts reach their capacity limits.

High profitability in continual use

Thanks to forward-looking technology, frequent bulb changes – and thus expensive down-times – are now a thing of the past. Comparative calculations show that the use of LED technology in comparison with conventional filament bulbs has usually paid for itself soon after the first bulb replacement.

There are no follow-on costs caused by the replacement of faulty lamps or bulbs. LED lamps are wear-free and maintenance-free. Reliability and economic feasibility are the convincing arguments in day-to-day operation.

Advantages of Hella LEDs at a glance:

- Long service life
- Wear-free and maintenance-free
- Vibration and shock proof
- High operational safety
- Dustproof and waterproof
- Can be cleaned with a high-pressure jet
- Minimum power consumption
- Increased safety thanks to quick switch-on behaviour of the light diodes
- Functional design
- Compact shapes





Illumination using xenon light. Xenon light makes the road brighter and illuminates a wider area. Hazards are recognised earlier.

Hella xenon light turns night into day

Extract from a survey carried out by the opinion research institute Emnid:

- 94 % of all users of xenon light had a positive opinion of xenon light, brightness (42%) and general illumination (35%) were factors mentioned in particular here.
- 85 % of all users of xenon light said they were able to see better at night.
- 83 % of all users of xenon light would order their next car with xenon light.
- 80 % of all users of xenon light said they were able to see better in the rain with xenon light.

It was only the combination of high-performance electronics and state-of-the-art lighting technology that made this revolution in automotive lighting possible: xenon light for illumination of the road in daylight-like quality, even in darkest night. Xenon light is produced in gas discharge lamps. A light arc is ignited and kept lit between two exactly positioned electrodes. Hella has developed a sophisticated electronic ballast system to control this process.

And there are further decisive product advantages, too:

- A xenon lamp provides twice the light of an H7 bulb while consuming only 2/3 of the power
- The light colour similar to daylight prevents premature tiredness
- Illumination of the road and the edge of the road has been considerably improved
- Xenon light is more in line with human seeing habits than other light sources
- Work lamps with xenon light make working in the dark easier, thus speeding up working processes.

The sum of all these positive points speaks for itself and for Hella xenon light:

More road safety and driving comfort for professional drivers. And for all other road users, too.

Alongside conversion sets for main headlamps, xenon technology is also used in optical warning systems and work lamps – thus ensuring a high degree of warning effectiveness and working safety.

Thus with xenon technology, Hella has created a new dimension in terms of retrofitting and conversion business for the after-market and workshops.

Xenon light: more light = more safety



All xenon and bi-xenon systems have integrated dynamic headlamp levelling and a lens cleaning system.



Mark 4 ballast with a xenon bulb.



DynaView® – curves are getting brighter

For the first time ever, a driving lamp is able to illuminate corners and bends in the road independently and "intelligently": Its name: DynaView®. It provides quite a few safe metres and takes considerable pressure off the optic nerves – less tension for better driving.

The DynaView® system actually comprises four headlamps, two of which provide the conventional main beam light and one of the other two – depending on the direction of the curve – illuminates the curve ahead.

This bend lighting is controlled by an intelligent chip which permanently calculates the respective transverse acceleration of the vehicle and switches the additional bend lamp on automatically – completely independently of external technology such as GPS-controlled systems.

The result is sensational and amazing at the same time: "Driving blind" into the unknown is now a thing of the past; night-time driving along winding roads will become much safer and more relaxed. The DynaView® auxiliary lamps are based on the revolutionary VARILIS technology, which turns lighting and lamp systems into independent and intelligent functional units. The introduction of DynaView® to the market means an enormous turnover potential in the field of retrofitting for the aftermarket and garages.



Always one look ahead: DynaView® for safe bend driving.





Modern truck electrics from Hella – a convincing range of products

Today, we are the number one lighting expert, but Hella is a strong partner for the aftermarket and garages in the field of electrics, too.

The Hella range for truck electrics provides suitable products for all areas of application. It includes product ranges which are permanently being adapted and extended in dialogue with our customers – and many products that provide new, innovative impulses. Hella's proverbial quality in the area of lighting, which is common knowledge, is of course the standard applied to all electrics products, too. Our good name stands for best performance, everything from a single source – a perfect match!

Hella electrics products cover a wide range with a high market volume:

- Comprehensive range of starters and alternators
- Wide range of relay devices and flasher units
- Cover of international standards for plugs and sockets
- Comprehensive selection of horns and fanfares.

All Hella products have been designed for safe heavy-duty use – no excuses.

Original Equipment quality for retrofitting – there's nothing to it with Hella products!

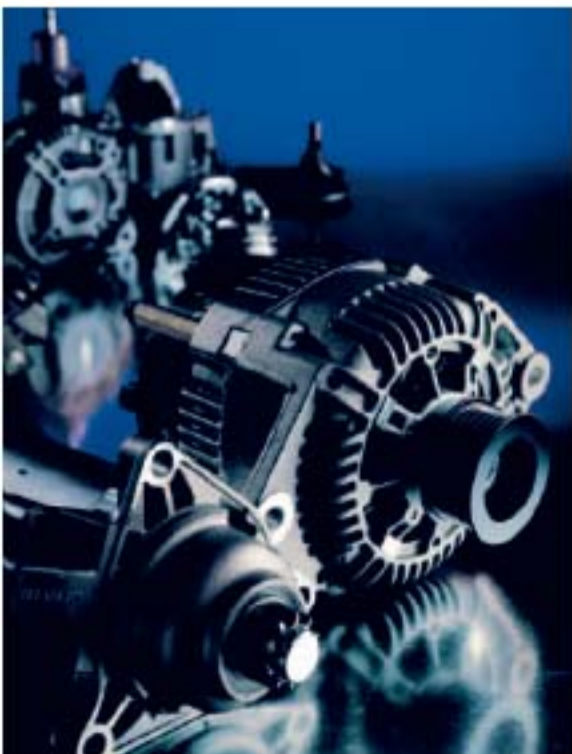



Conventional main beam light: the bend remains in darkness.

DynaView®: The driver can see where he's going, even in bends.

Bend lighting – DynaView®

DynaView® – the driving lamp system with integrated bend lighting

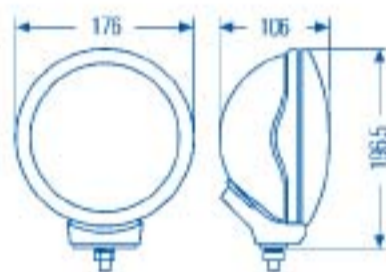

DynaView®

24 V set

1F5 008 690-811

The lower half of the dual reflector is responsible for the precise illumination of the bend.

DynaView® is a professional system and is suitable for heavy-duty use thanks to the materials used.

At the heart of the intelligent switching technology: the transverse acceleration sensor.

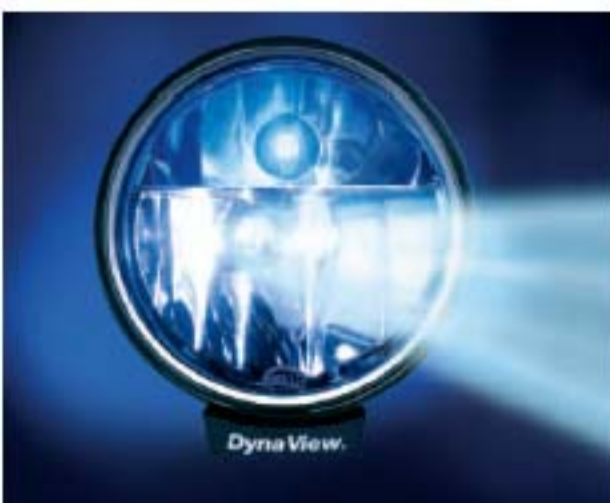

Hella auxiliary lamps - Profi-Line Xenon

A must for professionals - the ultimate light for real gains in safety and driving comfort with Hella auxiliary lamps

Xenon - Profi-Line

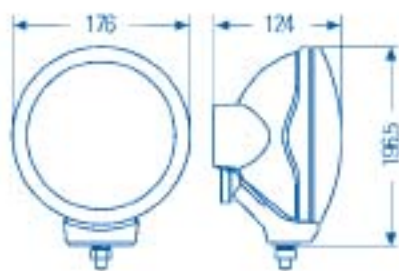

Rallye 1000 Xenon

White light, almost as bright as daylight for a good look at the road ahead. With the latest free-form reflector technology and crystal-clear outer lens as well as a red outer ring.

1F5 008 273-061



Luminator Xenon

The ultimate in light. Long-range, intensive, tremendous light power almost as bright as daylight - this will fill all professionals and frequent drivers with enthusiasm.

1F8 007 560-571

Protective grille

9HG 148 995-001

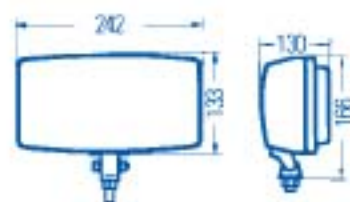

Jumbo Xenon

Large rectangular auxiliary lamps with white light output, almost as bright as daylight. The black metal housing with the red housing frame adds a striking optical feature to your vehicle.

1FE 002 537-461



new

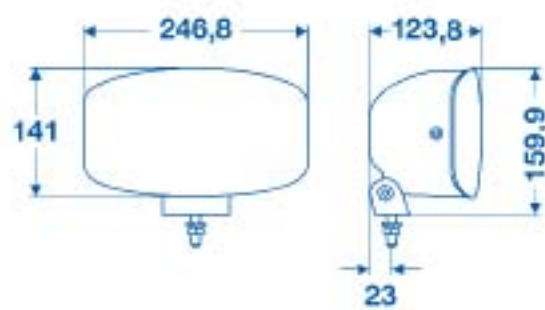

Jumbo 320 Xenon

The innovative advanced development of the world famous Jumbo Xenon. Extremely sturdy design, with the modern, innovative clear-glass look. FF magnesium reflector design with an even better light output.

Position light function by means of 6 white high-power LEDs. Waterproof electronic box. Installation upright or pendant. The extended and separable high-energy cable harness makes flexible and easy installation possible.

1FE 008 773-051

Hella auxiliary lamps – Profi-Line Halogen

Lonely night-time drives are heavy going! Those who can rely on Hella lighting are lucky!

Halogen – Profi-line

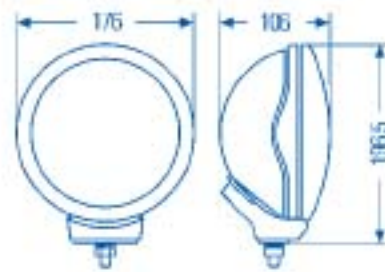

Rallye 1000 FF

The successor to the already legendary Rallye 1000. With vastly improved light output thanks to the FF reflector. Active, safe light when driving in the dark. For professionals who spend a lot of time on the road.

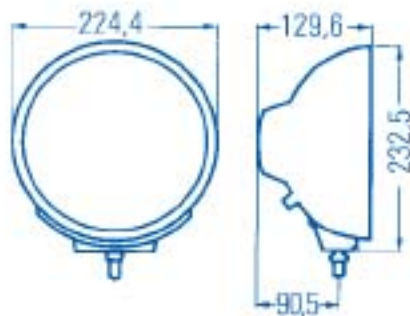

Luminator Metal

Latest lighting technology in a sturdy zinc die-cast housing. A valuable addition for every trucker.

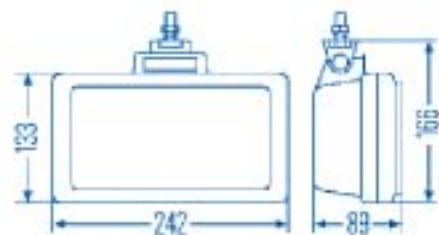

Jumbo 220

Experienced truckers swear by it. Optimum view thanks to powerful light. The black grained and impact-resistant housing has been designed for upright or pendant mounting. With fixture for two-point attachment.

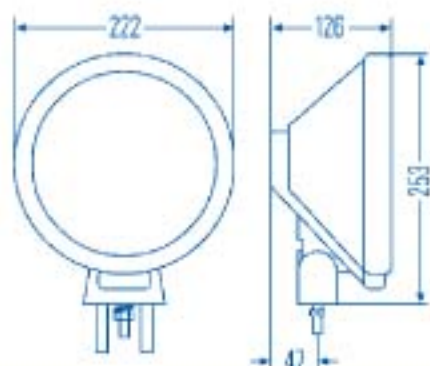

Rallye 3000

The Rallye 3000 has been a tried and trusted partner of truckers for years now. In proven FF lighting technology, added safety for professional drivers.

new

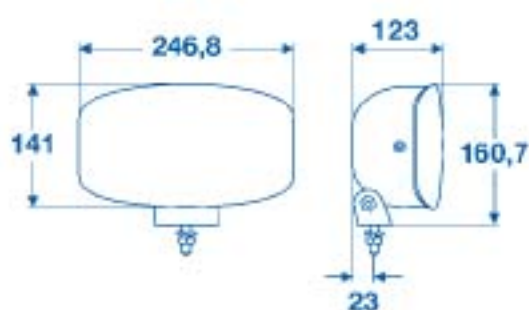

Jumbo 320 FF

The innovative advanced development of the world famous Jumbo 220. Extremely sturdy in a modern, innovative clear-glass design. FF magnesium reflector design with even better light output. Installation upright or pendant. Proven attachment technology.

Jumbo 320 FF (housing colour black)

Driving lamp (Ref. 37.5)	1FE 008 773-001
Driving lamp with position light (Ref. 37.5)	1FE 008 773-041
Driving lamp (Ref. 17.5)	1FE 008 773-011
Proven auxiliary lamp technology	1NE 008 773-031

① Rallye 1000 FF (housing colour silver/black)

Driving lamp (Ref. 37.5)	1F5 008 273-001
Driving lamp (Ref. 17.5)	1N5 008 273-011
Driving lamp (Ref. 37.5) with position light	1F5 008 273-071

② Luminator Metal (housing colour silver/black)

Driving lamp (Ref. 37.5) with position light	1F8 007 560-041
Fog lamp	1F8 007 560-031
Protective grille	9HG 148 995-001

③ Jumbo 220 (housing colour black)

Driving lamp (Ref. 37.5) black frame	1FE 006 300-041
Driving lamp (Ref. 37.5) chrome frame	1FE 006 300-001
Fog lamp, black frame	1NE 006 300-051
Fog lamp, chrome frame	1NE 006 300-011

④ Rallye 3000 (housing colour black)

Driving lamp (Ref. 37.5)	1F8 006 800-111
Driving lamp (Ref. 37.5) with position light	1F8 006 800-191
Fog lamp	1N8 006 800-001
Protective grille (set)	9HG 142 050-801
Universal cable harness	8KA 002 309-811



Hella auxiliary lamps – Profi-Line Blue

A combination of tried and trusted lighting technology and an attractive appearance

Blue Edition – Profi-Line

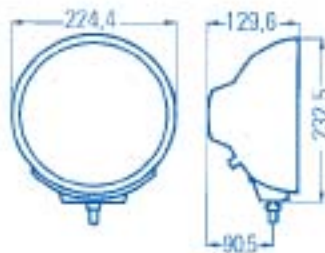

Luminator Chromium Blue

The Luminator among the chrome headlamps is now also available in blue: extremely resilient metal, treated with high-quality chrome-plating. An optimum combination of function and aesthetics.

with position light

1F8 007 560-131

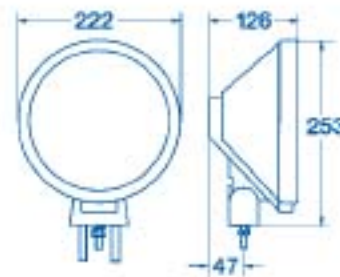

Rallye 3000 Blue

Tried and trusted FF lighting technology in the cool blue design. Silver-coloured ring with blue design stripes.

with position light

1F8 006 800-221

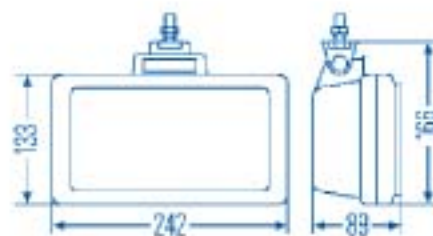

Jumbo 220 Blue

High-grade headlamp with full lighting performance. The blue-painted cover lens projects the light onto the road without any loss. Ideal for trucks, transporters and larger vehicles. Installation upright or pendant.

1FE 006 300-261



Jumbo 320 Blue

Powerful new large-scale auxiliary lamp in the blue-look. Extremely sturdy in its modern, innovative clear-glass look, it matches the design of the new vehicle front-ends just perfectly. An ideal complement for the standard driving light. The Jumbo 320 Blue combines innovative lighting technology and its blue design with the safety of a high-quality driving lamp. There is no light loss caused by the blue lens.

1FE 008 773-061

Xenon light for Mercedes-Benz Actros and Scania BR 4

Twin headlamps for professionals: Hella xenon light for trucks

This upgrade will allow you to drive long stretches at night with daylight-like quality: xenon light will get you to your destination safely.

This powerful light, which is as bright as daylight, makes driving on any road in the dark much less stressful and tiring than with conventional halogen light. No matter whether you own your own truck or are responsible for a whole fleet of vehicles: you always have to put safety first. To actively support your efforts, Hella has now developed a headlamp system using xenon dipped beam light. So you can switch quickly and comfortably to more safety.



All product features at a glance:

- Xenon dipped beam headlamp
- Halogen driving lamp
- Original plug connection
- Headlamps can be adjusted from the front
- Professional cable harness
- Design trim can be painted in the required colour
- Fastening material and mounting instructions, including a sturdy, corrosion-protected carrier frame with pre-mounted headlamps.



MB Actros (→ 10/02)

For all vehicles with vehicle levelling

Xenon dipped beam light, halogen main beam light and position light
1DL 008 609-811

Xenon dipped beam light, halogen main beam light and indicator light
1DL 008 609-831

Halogen dipped beam light, halogen main beam light and position light
1DL 008 609-851

Halogen dipped beam light, halogen main beam light and indicator light
1DL 008 609-871

Lens cleaning system
(required for xenon versions)
8WS 008 623-001

Scania P94 -T164 (BR 4)

Xenon dipped beam light, halogen main beam light
1DL 008 735-811

Lens cleaning system
(required for xenon versions)
8WS 008 680-001

Automatic headlamp levelling
(required for vehicles without vehicle levelling feature)
8XX 008 614-101



Main headlamps for trucks

Good light for safe driving - Hella Original headlamps provide you with the optimum view for almost all applications.



For DAF CF/LF/XF:

CF 65, CF 75, CF 85 (01/01 →)

XF 95 (11/02 →) LF 45, LF 55:

left, with indicator light	1EJ 008 311-411
right, with indicator light	1EJ 008 311-421



For DAF 85 XF (from 04/97 → 10/02)

for vehicles with or without headlamp levelling

left	1AG 007 660-091
------	-----------------

for vehicles with or without headlamp levelling

right	1AG 007 660-101
-------	-----------------

Cover lenses

left	9ES 147 315-005
right	9ES 147 316-005



For DAF F 65 CF, F 75 CF, F 85 CF (02/98 → 12/00)

without electric headlamp levelling

left	1AG 007 660-011
------	-----------------

without electric headlamp levelling

right	1AG 007 660-021
-------	-----------------

Cover lenses

left	9ES 147 313-001
right	9ES 147 314-001



For Volvo FH 12, FH 16 (10/93 → 09/97)

H4 main headlamp	1AG 006 898-041
------------------	-----------------

FH 12: (10/97 → 12/01)

FH 16: (10/97 → 12/01)

H4 main headlamp	1AG 006 898-081
------------------	-----------------

For Volvo FM 7, FM 12 (10/98 → 12/01)

H4 main headlamp	1AG 006 898-081
------------------	-----------------



For MAN F2000 (01/94 →)

MAN F2000 (08/95 →)

with position light and separate indicator light

left **1D3 009 027-011**

right **1D3 009 027-021**



For Scania P94-T164 (model range 4) (09/96 →)

with indicator/position light, (white) and
suitable for electric headlamp levelling device

left **1EG 007 150-091**

with indicator/position light, (white) and
suitable for electric headlamp levelling device
right **1EG 007 150-101**



For Mercedes-Benz MK-SK series

MK-SK series (09/98 →)

H4 main headlamp,
with indicator light, unsuitable for headlamp
levelling device

left **1EH 002 658-331**

H4 main headlamp,
with indicator light, unsuitable
for headlamp levelling device

right **1EH 002 658-341**



For Mercedes-Benz Actros

Actros 1831 - 4148 (09/96 →)

H4 main headlamp, without indicator light,
without headlamp levelling

left **1EH 008 688-011**

H4 main headlamp, without
indicator light, without headlamp levelling

right **1EH 008 688-021**



Halogen

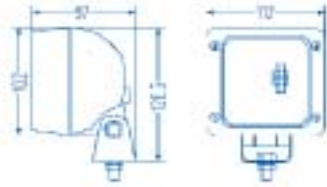

Ultra Beam FF

Small compact work lamp with powerful and homogeneous illumination without handle

1GA 007 506-021

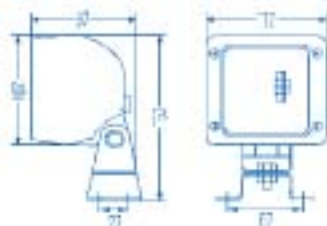

with vibration-reduced base, without handle

1GA 007 506-011

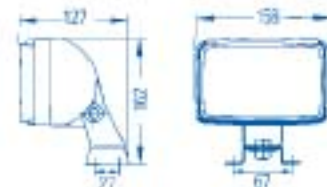

Double Beam FF

Powerful work lamp with twin FF reflectors for 2 halogen bulbs. For extremely large-surface and homogeneous illumination

without handle

1GA 006 991-041

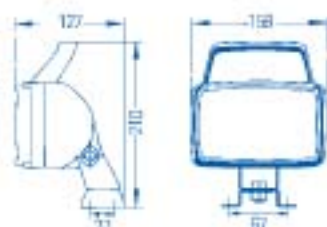

with handle

1GA 006 991-031

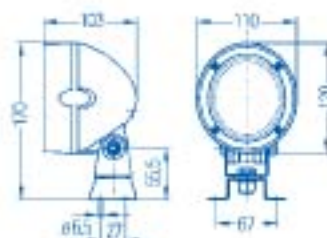

Mega Beam FF

With FF reflectors for large-surface and homogeneous illumination. Brilliant look thanks to transparent cover lens.

1GM 996 134-051

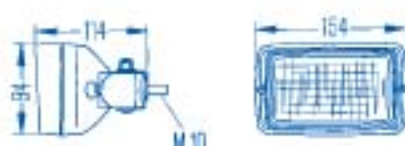

Picador FF

With FF reflectors for large-surface and homogeneous close-range illumination.

1GA 006 875-001

Rotating beacons and strobe-type beacons

Optimum warning effect thanks to innovative signalling systems

Hella supplies a wide range of innovative and high-quality beacons for trucks with numerous different mounting attachment possibilities. Making Hella your ideal partner for powerful signals wherever you require an outstanding warning effect.

KLX 7000 strobe-type beacons

The Hella strobe-type beacons fulfil toughest demands in terms of warning effectiveness. They use the latest lighting technology and are available either for permanent installation, as a flexible version with pipe socket mounting or as magnetic beacons

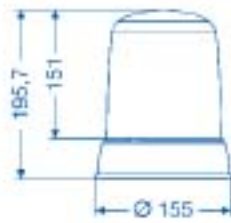

KLX 7000 F

The KLX 7000 for permanent installation is the ideal solution whenever the toughest demands have to be met in terms of warning effectiveness. There are two hole patterns (130 mm/107 mm) available for this version. This makes the lamp compatible with all usual attachment dimensions, so that replacement is not a problem. Installation and removal are extremely easy thanks to the simple plug-type system.

2RL 008 181-111

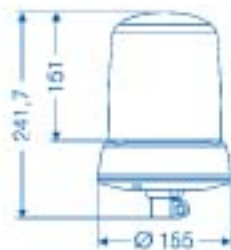

KLX 7000 FL

The KLX 7000 Flexible is equipped with a flexible pipe socket. The flexible base buffers jolts and returns the beacon to its original position with no harm done. Particularly important here: the light dome is made of impact-resistant PC and prevents the lamp being damaged by knocks and jolts.

2RL 008 183-111

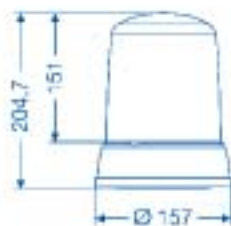

KLX 7000 M

The KLX 7000 with magnetic attachment is ideally suited for applications where best possible warning effectiveness is only required for a limited time. The lamp is equipped with 5 powerful magnets which guarantee high adhesive force on the vehicle roof. The power supply is via a spiral cable connected to the cigarette lighter.

2RL 008 182-111

KL 7000/8000

High-tech for optimum signalling effect – The KL 7000/8000 series meets highest technical requirements.

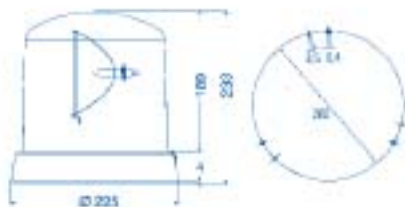

KL 8000 F

This lamp has been especially designed for large trucks and special vehicles.

2RL 008 065-111

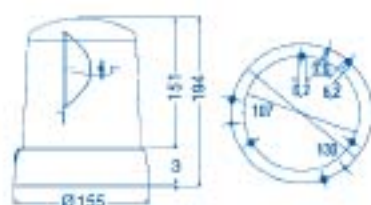

KL 7000 F

The ideal solution for all vehicles that have to be constantly ready for action.

2RL 008 061-111

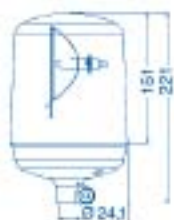

KL 7000 R

The beacon can be quickly mounted on all pipe socket attachments with built-in power socket. In addition, the KL is screwed to the pipe socket using an Allen screw to prevent theft.

2RL 008 060-111

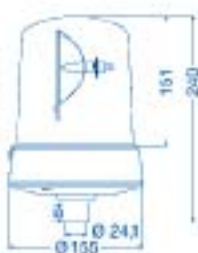

KL 7000 FL

The flexible body base buffers even heavy jolts and always returns the beacon to its optimum position. The impact-resistant Macrolon light dome prevents the dome cracking.

2RL 008 063-111



KL 7000 M

The high adhesive force of the five individual magnets guarantees a secure hold on the vehicle roof. The voltage supply is via the 2.5 m long spiral cable with DIN plug for the cigarette lighter – the ideal solution for flexible use.

2RL 008 062-111

KL Rotaflex and Rotafix

The shape, attachment and material quality of the KL Rotaflex and Rotafix beacons can meet the most demanding requirements.



Rotaflex

Pipe socket attachment, light exposure 74 mm. Including bulb. The return force of the flexible body base has been designed in such a way that the lamp is returned to its original position even after it has been tilted for some time. The Macrolon light domes are extremely impact-resistant.

2RL 006 846-011



Rotafix

The KL Rotafix has also been equipped with impact-resistant Macrolon light domes. The high adhesive force of the magnet makes secure and flexible use of the lamp possible.

for permanent installation

2RL 007 337-011



with magnetic attachment for flexible use

magnetic attachment

2RL 007 337-031



Optical warning systems

Powerful lighting systems for the optimum warning of the site of an incident: OWS and OWS xenon

Quite often, individual beacons are not enough for an optimum signal effect. The positioning of two beacons on the outside edges of the vehicle roof achieves excellent recognition: on the one hand thanks to the light signals from the beacons, on the other thanks to xenon technology.

Construction vehicles, road cleaning and breakdown services, special vehicles with excessive length or width, airport vehicles etc. are all typical examples of use for the Hella OWS.

OWS-X strobe-type system

The OWS-X has a replaceable X1-xenon standard flash tube and thus ensures the most effective warning signal possible. Different length versions allow the OWS-X to be adapted to a wide range of vehicle roofs. In addition, all Hella OWS systems include advertising panels which can be designed individually as required.



OWS 1400 strobe-type technology

24 V, 1400 mm wide

2RL 007 900-241



OWS 1600 strobe-type technology:

24 V, 1600 mm wide

2RL 007 900-631

OWS rotating mirror technology

The OWS with rotating mirror technology guarantees optimum recognition, since the light signals from the two beacons are radiated at different time intervals. There are different lengths available with advertising space for individual lettering for these systems, too.



OWS 1400 rotating mirror

24 V, 1400 mm wide

2RL 007 900-211



OWS 1600 rotating mirror

24 V, 1600 mm wide

2RL 007 900-611



Seven-chamber lamps

Hella seven-chamber lamps for trucks: by consistently extending the range of lamps available, Hella has increased market cover to 90% of all applications in this field. Giving you variety and quality from a single source.



- 1= ground
- 2= S/KUR/SMLR
- 3= ZR
- 4= BL
- 5= B
- 6= NES
- 7= -

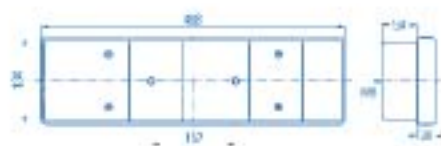

For MAN TG-A (04/02 →) and DAF F 65 CF, F 75 CF, F 85 CF, XF 95 (01/01 →)

- right 2VP 008 204-241
- with numberplate light 2VD 008 204-251



- 1= BL
- 2= S/KUR/SMLR
- 3= B
- 4= NES
- 5= ZR
- 6= -
- 7= -
- 8= ground

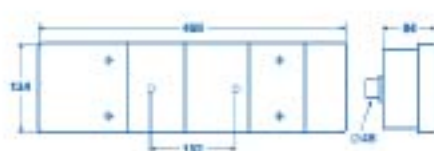

For MAN F2000 (10/94 →) and Scania 3 series (01/88 → 12/95)

- left/right 2VP 008 204-061
- with numberplate light 2VD 008 204-071



- 1= BL
- 2= S/KUR/SMLR
- 3= B
- 4= NES
- 5= ZR
- 6= -
- 7= -
- 8= ground

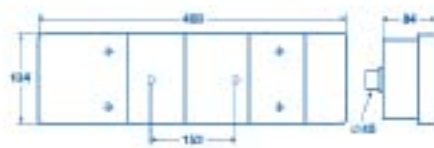

For DAF F 65 (01/93 → 02/98), F 75 (01/92 → 02/98), F 85 (01/93 → 02/98), F 95 (09/87 → 03/97)

- left/right 2VP 008 204-161
- with numberplate light 2VD 008 204-171



- 1= ground
- 2= S/KUR/SMLR
- 3= ZR
- 4= BL
- 5= B
- 6= NES
- 7= -

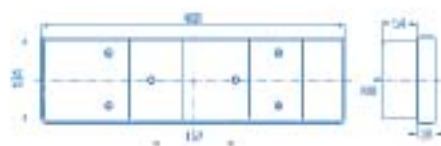

For Renault Magnum and Premium

- right 2VP 008 204-221
- with numberplate light 2VD 008 204-231



- 1= UR/SML
- 2= BL
- 3= B
- 4= ZR
- 5= -
- 6= -
- 7= -
- 8= ground
- 9= NES
- 10= S

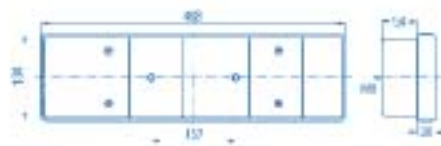

For Iveco Stralis (02/02 →), Eurostar (01/93 →), Eurotech (01/92 →), Eurocargo (01/91 →), Eurotraker (01/93 →)

- left/right 2VP 008 204-181
- with numberplate light 2VD 008 204-191



- 1= BL
- 2= S/KUR/SMLR
- 3= B
- 4= NES
- 5= ZR
- 6= -
- 7= -
- 8= ground

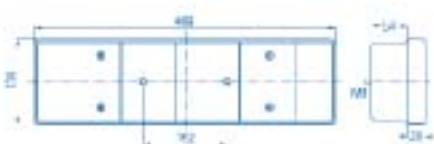

For VW pickup (05/96 →)

- with numberplate light and rear fog lamp
- left, with numberplate light 2VP 008 204-131
- right 2VD 008 204-121



- 1= ground
- 2= S/KUR/SMLR
- 3= ZR
- 4= BL
- 5= B
- 6= NES
- 7= -

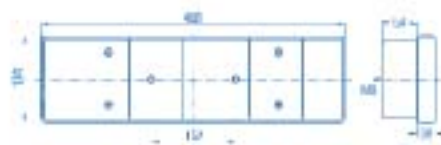

Universal version

- right, with numberplate light 2VP 008 204-201
- left 2VD 008 204-211
- lens for all the versions illustrated: 9EL 152 889-001

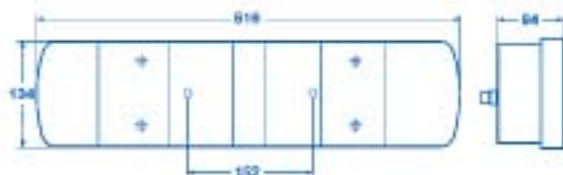

- 1= ground
- 2= BL
- 3= B
- 4= S/K/UR/SMLR
- 5= ZR
- 6= NES
- 7= -

For Volvo FH (→ 10/90), FM (10/90 →)

- left/right, without numberplate light **2VP 008 205-031**
- left, with numberplate light **2VD 008 205-051**
- Left-hand traffic
- right, with numberplate light **2VD 008 205-041**

For Scania 4-series (01/96 →)

- left, with numberplate light **2VD 008 205-011**
- right, with numberplate light **2VD 008 205-021**

Lens for -031, -041, -051, -011, -021

9EL 152 884-001

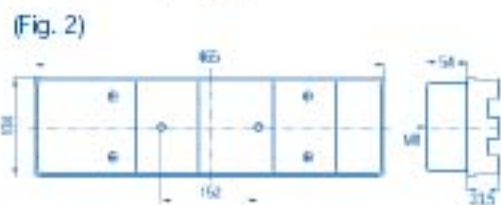
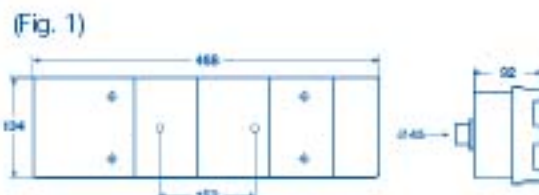

- 1= BL
- 2= S/K/UR/SMLR
- 3= B
- 4= NES
- 5= ZR
- 6= -
- 7= -
- 8= ground

For MB Vario pickup (09/96 →) and Atego (04/98 →) bis 18 t

- right (Fig. 1) **2VP 008 204-081**
- left (Fig. 2), with numberplate light **2VD 008 204-091**

For MB Sprinter pickup (02/95 → 03/00) and Facelift (04/00 →)

- With rear fog light and numberplate light
- without central plug **2VD 008 204-111**
- 2VP 008 204-101**

Lens for -081, -091, -111 und -101

9EL 152 891-001

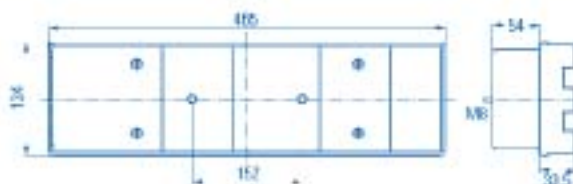

- 1= BL
- 2= S/K/UR/SMLR
- 3= -
- 4= NES
- 5= ZR
- 6= Masse
- 7= B
- 8= -



- 1= BL
- 2= S/K/UR/SMLR
- 3= -
- 4= NES
- 5= ZR
- 6= ground
- 7= B
- 8= -

For MB Actros (09/96 →), SKN (10/96 →) and Atego from 18 t (10/97 →)

- with 7-pin central plug at the side
- left (Fig. 1), with numberplate light **2VD 007 500-411**
- right (Fig. 2) **2VP 007 500-421**



- 1= BL
- 2= S/K/UR/SMLR
- 3= -
- 4= NES
- 5= ZR
- 6= Masse
- 7= B
- 8= -



- 1= BL
- 2= S/K/UR/SMLR
- 3= -
- 4= -
- 5= ZR
- 6= ground
- 7= B
- 8= -

For MB MK-SK series (11/94 →)

- With yellow reflex reflector at the side, including wire harness and round plug
- left (Fig. 3), with numberplate light **2VD 007 500-091**
- right (Fig. 4) **2VP 007 500-101**

- left (Fig. 3), with numberplate light **2VD 007 500-111**
- right (Fig. 4) **2VP 007 500-121**

Lens for:

- 091/-111/-411 **9EL 134 296-041**
- 101/-121/-421 **9EL 134 296-051**

Hella multiple function lamps

Hella supplies a wide range for the most varied of applications, with the range being continually extended.

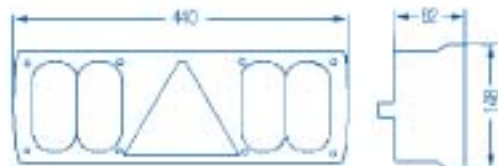

Seven-chamber lamp for 24 V trailers from 3.5 t

including Krone trailers or semitrailers with integrated triangular reflex reflectors, with PG threaded connection

left	2VP 340 450-031
right	2VP 340 450-021
lens	9EL 340 208-001

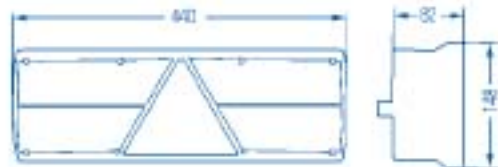

Seven-chamber lamp for 24 V trailers

including Kögel trailers, with integrated triangular reflex reflectors, with pre-fitted heavy-duty bulbs

left	2VP 340 450-151
right	2VP 340 450-141

lens, right/left:	9EL 340 208-021
-------------------	-----------------

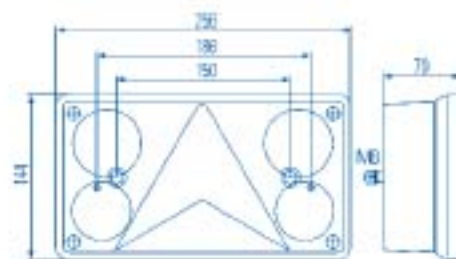

Combination rear lamp for trailers

and semitrailers with restricted attachment space, from 0.75 t, with integrated triangular reflex reflector, with socket, without numberplate light

left	2VP 340 400-141
right	2VP 340 400-151
lens left	9EL 340 203-011
lens right	9EL 340 203-001

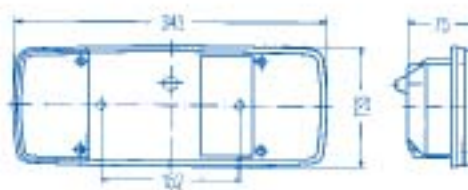

Five-chamber lamp

For twin-bulb fitting in the tail light, without numberplate light, without reflex reflector

left	2SK 003 567-651
right	2SK 003 567-661
with numberplate light, left	2SL 003 567-691
with reflex reflector, left	2SK 003 567-111
with reflex reflector, right	2SK 003 567-121

Lens for -651/-661/-691	9EL 122 772-001
-------------------------	-----------------

Lens for -111/-121	9EL 122 689-021
--------------------	-----------------



Combination rear lamp for MB LN1

Pickup vehicles and box-type trucks (01/86 → 04/96)

Vario/special vehicles (05/96 →)

TN pickup vehicles (03/89 → 06/95) und

Atego from 18 t (10/97 →) with side lining (with GGVS)

with numberplate light, left	2VB 004 887-011
------------------------------	-----------------

with reversing light	
----------------------	--

without numberplate light, right	2VP 004 887-021
----------------------------------	-----------------

without reversing light	
-------------------------	--

without numberplate light, left	2VA 004 887-031
---------------------------------	-----------------

Lens for -011/-031	9EL 131 420-001
--------------------	-----------------

Lens for -021	9EL 131 420-011
---------------	-----------------



Five-chamber lamp

with 6-wire cable, 1.40 m long, 6-pin plug and 24 V bulbs

left/right **2SK 340 101-001**

with additional side marker lamps:

left/right **2SK 340 101-011**

lens **9EL 340 201-001**

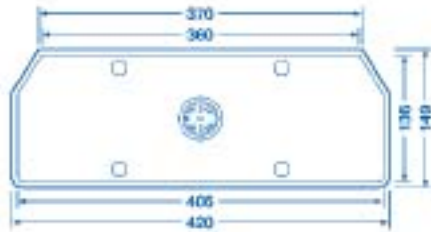

Combination rear lamp

With 7-pin plug and pre-fitted 24 V bulbs

With numberplate light

left **2VD 008 789-011**

right **2VD 008 789-061**

Without numberplate light

left **2VP 008 789-051**

right **2VP 008 789-021**

Lens for all versions **9EL 158 993-001**

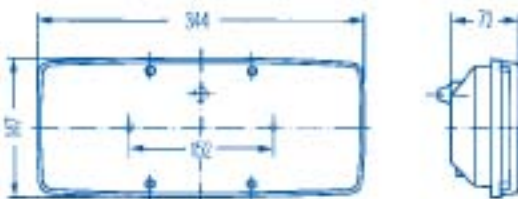

Tail-brake-indicator lamp

Without numberplate light

left **2SD 003 167-011**

right **2SD 003 167-021**

With numberplate light

left **2SE 003 167-031**

Lens **9EL 147 747-001**

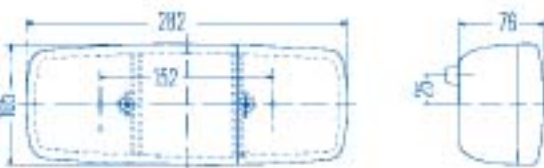

Tail-brake-indicator lamp

left **2SD 001 699-511**

right **2SD 001 699-061**

With numberplate light

left **2SE 001 699-071**

lens **9EL 109 139-001**

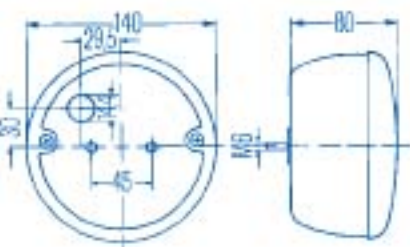

Tail-brake-indicator lamp

2SD 001 685-211

with numberplate light (with GGVS) **2SD 001 685-201**

with vibration-reduction (with GGVS) **2SD 001 865-231**

with numberplate light and

vibration reduction (with GGVS) **2SD 001 685-221**

lens **9EL 113 324-001**



Red position and clearance lamps

for flush-fitting on the rear



Clearance lamps

with bent rubber arm,

for upright surface-mounting

2XS 950 071-031

Without rubber arm

2XS 955 031-001



Clearance lamp

with straight rubber arm

2XS 955 232-001

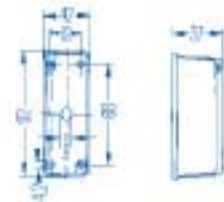

Clearance lamp (with GGVS)

without rubber attachment (with GGVS) 2XS 005 020-001

with rubber attachment (with GGVS) 2XS 005 020-011

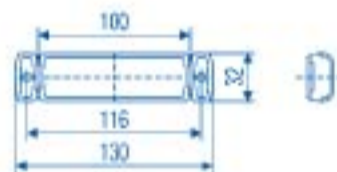

Clearance lamp with reflex reflector using LED technology

For horizontal and vertical surface-mounting

with 0.5 m cable 2TM 008 645-061

with 5.0 m cable 2TM 008 645-071

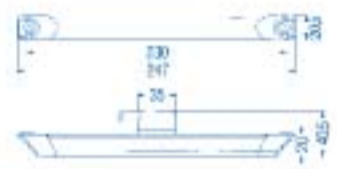

Clearance lamp using LED technology

For horizontal or vertical surface-mounting

2XS 008 078-001



Clearance-position lamp using LED technology

with 0.5 m cable

2XA 959 610-401

with 5.0 m cable

2XA 959 610-411

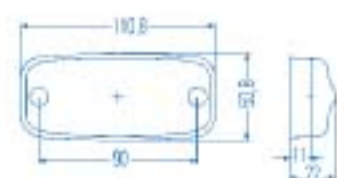

Clearance lamp using LED technology

with 0.5 m cable

2TM 963 639-317

White position and clearance lamps

for flush-fitting at the front

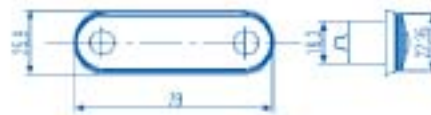

Position lamp

Flush-fitting version

with 0.5 m cable

2PF 959 590-401

with 5.0 m cable

2PF 959 590-411

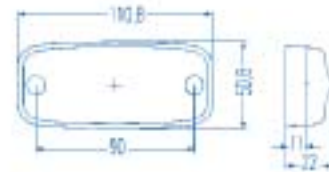

Position-clearance lamp using LED technology

with reflex reflector for horizontal surface-mounting

with moulded electric lead

with 0.5 m cable

2PG 963 639-401

with 5.0 m cable

2PG 963 639-411

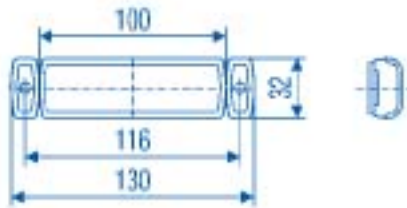

Position lamp using LED technology

with reflex reflector for horizontal

and vertical surface-mounting

with 0.5 m cable

2PG 008 645-041

with 5.0 m cable

2PG 008 645-051

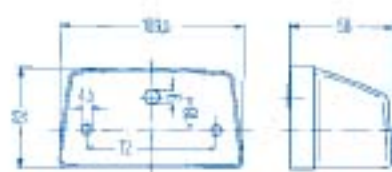

Numberplate lamp

black body

2KA 003 389-061

grey body

2KA 003 389-101

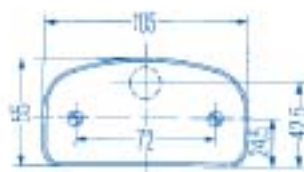

Numberplate lamp

2KA 001 386-231



Numberplate lamp

2KA 998 523-001

Side marker lamps

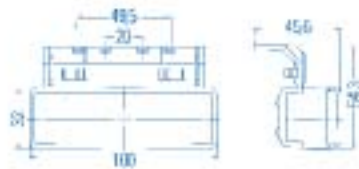

LED side marker lamp

with clip-on, angular "universal" bracket

2PS 008 643-031

Also available with clip-on angular bracket for "lengthways" and "crossways".

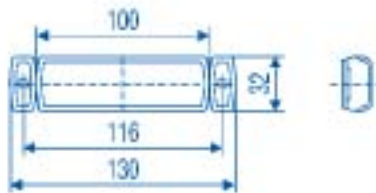

LED side marker lamp

for horizontal surface-mounting with quick-link cable for contacting a 2-wire flat cable, complete with clamp

with 0.3 m cable

2PS 008 645-611

with 1.3 m cable

2PS 008 645-621

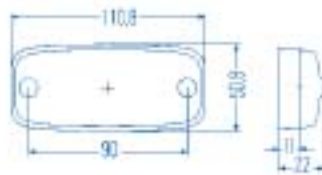

LED side marker lamp

With reflex reflector

without bracket

2PS 963 639-011

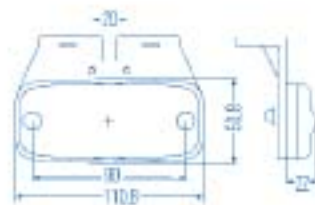

with bracket

2PS 963 639-071

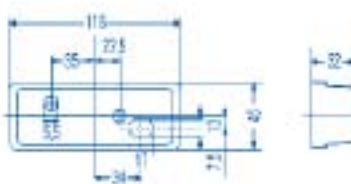

Side marker lamp

with reflex reflector

without bracket

2PS 003 748-121

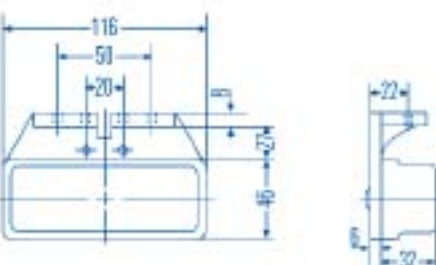

with bracket

2PS 003 748-161

Reflex reflectors

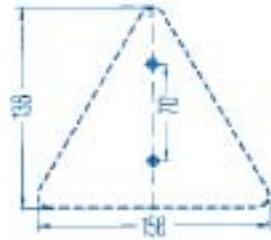

Triangular reflex reflector, red

8RA 002 020-001

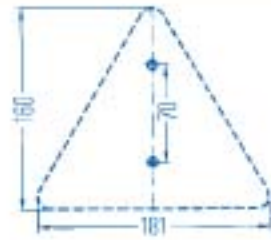

Triangular reflex reflector, red,
in four sections

8RA 003 503-001



Reflex reflector, round

Ø 60 mm self-adhesive

red 8RA 002 014-081

amber 8RA 002 014-101

white 8RA 002 014-091



Reflex reflector, rectangular

Ø 94 x 44 mm, self-adhesive

red 8RA 003 326-031

amber 8RA 003 326-041

white 8RA 003 326-051



Lamp for hydraulic loading platform, using LED
technology

2BA 008 260-001

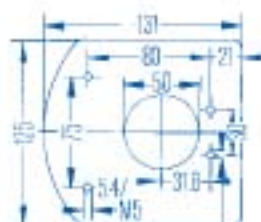

Lamp for hydraulic loading platform

with 4 holes (Ø 5.4 mm) for attachment screws

2BA 007 135-001

with attachment screws (M5 x 35)

and reinforced lens

2BA 007 135-011

Hella hazard lamps, warning triangle

See and be seen. Powerful light signals, visible up to three kilometres away. Can withstand winds up to 9 on the Beaufort scale. Housing impact-resistant and splashwater-proof. GGVS and type-approved.



Safety warning flash lamp

Model 3003 ACCU

Always ready for use and on hand. With the engine running, the battery is charged via contacts in the charging bracket. Automatic on-board voltage switching 12/24 V.

Operating time in flashing mode 24 hours or 7 hours with the work light. Charging bracket and lead-gel battery are included in the scope of supply. Type-approved.

2XW 007 146-011



Model 3003

With attachment bracket (for battery operation by means of 5 mono-cell batteries, not included in the scope of supply). Type-approved.

2XW 007 146-001



Safety warning triangle

Extremely stable. Easy to set up. Type-approved.

With storage box.

8RW 341 421-001

Hella reading lamp

Ideal for reading routes and maps in the truck.



Reading light

Powerful glare-free light sources on flexible metal arms. Arm length 500 mm, 24 V operating voltage incl. xenon bulb 24 V/7.5 W

2AB 004 532-051

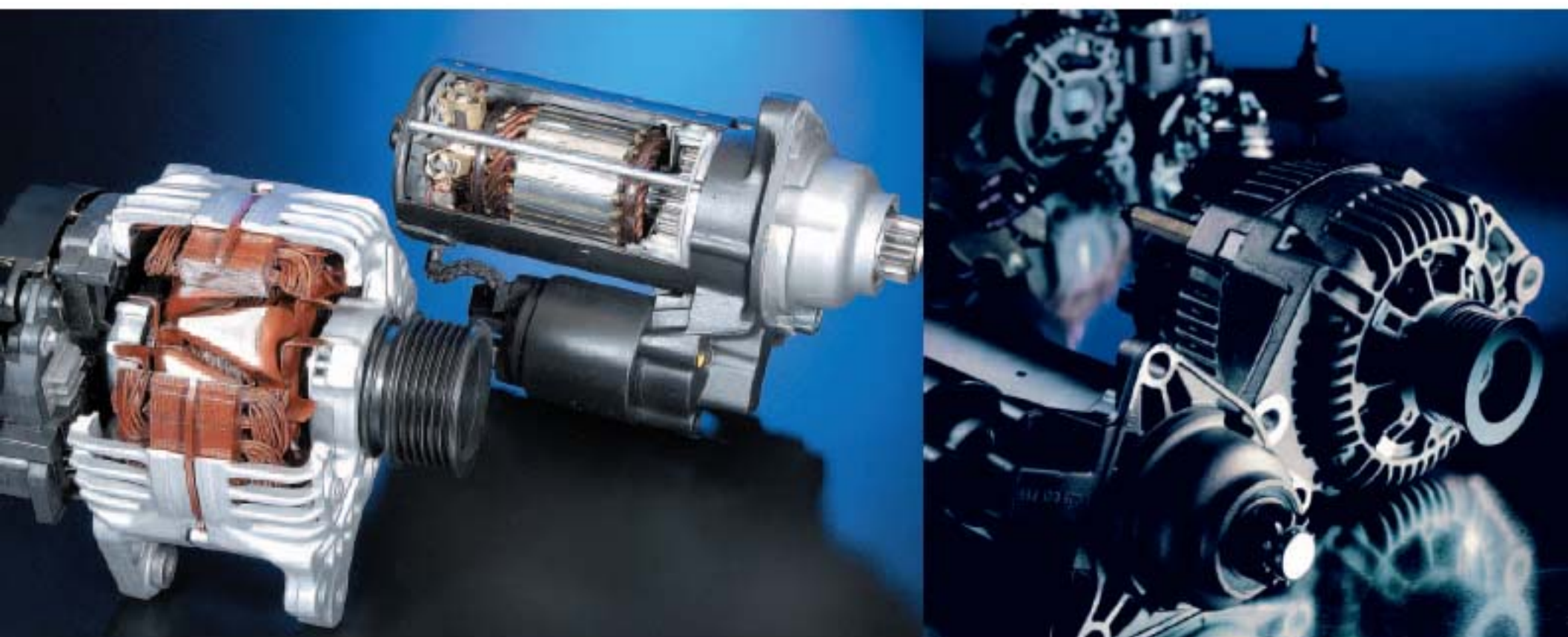

Starters and alternators for trucks

Hella supplies more than 100 starters and alternators for the most common applications on the market.

Hella remanufactures starters and alternators

The recycling of the units is carried out according to the quality requirements of vehicle manufacturers. It is subject to continuous quality control (certification ISO 9001:2000).

Hella supplies wholesaler and workshops with starters and alternators for the most common applications on the market. For Volvo FH 12 and FH 16; Mercedes Benz Actros; Renault Magnum; Scania L94 as well as various MAN and DAF models, for example.

All starters and alternators are dismantled into individual components, cleaned and tested. 100% of wearing parts are replaced. Before the unit leaves our factory, we give it a thorough test using state-of-the-art testing equipment.

In addition, our Technical Service department with expert hotline is always available to give you help and advice as and when you need it – a matter of course for Hella.





Horns and fanfares - powerful signals



Electro-fanfare TE 12

Loud warning signal in two tone versions. Metal housing with red plastic cover, black plastic bell mouth. With plain sliders. Bracket on the fanfare for attachment screw M8, can be turned through 90°.

Power consumption: 70 W per fanfare

Low tone 24 V, 400 Hz 114 mm

3FG 002 924-161

High tone 24 V, 500 Hz, 114 mm

3FG 002 924-171

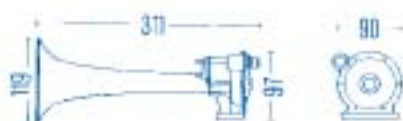

Pneumatic fanfare

For vehicles with pneumatic brakes, housing made of sturdy die-cast metal, black plastic bell mouth

Compressed air range: 6 – 8.3 bar,

Power consumption: 50 W

Sound level: 118 dB (A) 24 V, 400 Hz,

suitable for 10 mm compressed air hose

3PA 004 206-011



Pneumatic fanfare "Highway"

Two-tone sound, with chrome-plated housing, for vehicles with pneumatic brakes system.

Compressed air range 4 – 8.5 bar

3PB 005 411-001

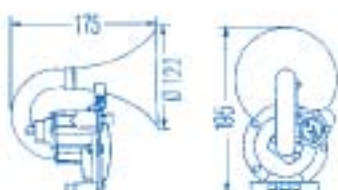

Pneumatic fanfare

With bent bell mouth, suitable for 8 mm compressed air pipe

24 V, 350 Hz

3PA 004 206-031



Relays

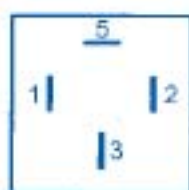

Make contact relay (mini-relay)

With resistor inductive interference voltage peak of the coil limited to < 90 V through parallel resistor. Load (at 80° C), 40 A at 24 V, 4-pin, 24 V

without bracket	4RA 007 957-001
with bracket	4RA 007 957-011



Make contact relay

4-pin, 24 V, 15 A max. load, with bracket and flat fuse insert

4RA 003 510-651

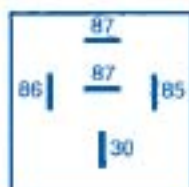

Make contact relay

5-pin, 24 V, 30 A max. load and 2 connections. Terminal 87 for switching pairs of consumers (e.g. auxiliary lamps).

4RA 003 510-141

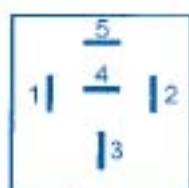

Changeover relay

With resistor inductive interference voltage peak of the coil limited to < 90 V through parallel resistor. With flat cable connections 6.3 mm. Load (at + 80° C), 40/20 A at 24 V, 5-pin, 24 V

without bracket	4RD 007 903-001
with bracket (also available with diode)	4RD 007 903-011

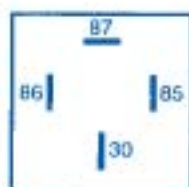

High-power make contact relay

4-pin, 24 V, 60 A max. load, with bracket

4RA 003 437-051

Flasher units

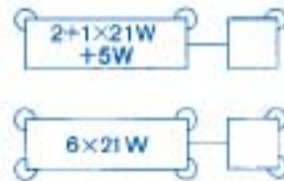
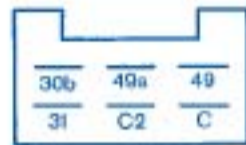

Flasher unit

Single-circuit flasher unit, direction indicator and hazard warning lights 6-pin, 24 V

2+1(6) x 21 W	4DM 003 944-041
3+1(8) x 21 W	4DW 003 944-051
2+1(6) x 21 W	4DM 006 475-051
3+1(8) x 21 W	4DM 006 475-071

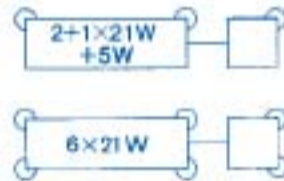
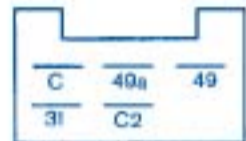

Flasher unit

5-pin, 24 V

4DM 003 474-001

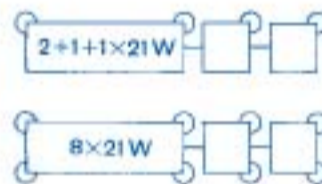

Triple-circuit flasher unit

direction indicator and hazard warning lights, 13-pin, 24 V

4DN 004 589-031

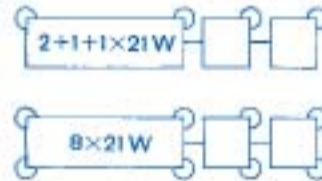

Flasher unit

2+1+1(8) x 21 W, 24 V

4DN 007 431-021

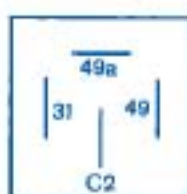

Flasher unit

24 V

4DM 003 390-031



Hella voltage reduction devices and load compensation devices

Hella voltage reduction devices

In some vehicles with an on-board mains voltage of 24 V it is often necessary to reduce the voltage to 12 V in order to be able to install various devices, such as radios or radio transmission and receiving sets, for example. Hella has a range of voltage reduction devices with different loads available: permanent

current 2 A, 4 A or 8 A over the whole range of voltage and temperature. To select the right voltage reduction device, simply add the current consumption of the consumers together and you will have the power you need.



Voltage reduction device 2 A

8ES 006 658-001

Technical details

Input voltage: 18 V – 30 V
Output voltage: 14 V +/- 3%
Output power: 28 W
Dimensions: 100 x 97 x 27 mm



Voltage reduction device 4 A

8ES 006 658-011

Technical details

Input voltage: 18 V – 30 V
Output voltage: 14 V +/- 3%
Output power: 56 W
Dimensions: 125 x 65 x 125 mm



Voltage reduction device 8 A

8ES 006 658-021

Technical details

Input voltage: 18 V – 30 V
Output voltage: 14 V +/- 3%
Output power: 112 W
Dimensions: 250 x 65 x 125 mm

Hella load compensation devices

A load compensation device determines the voltages of the two 12 V batteries. If the ground-side battery should show less voltage, the load compensation device provides compensation current. An LED indicates when the device is working.



Load compensation device

8ES 008 123-001

Technical details

Rated voltage: 24 V
Compensation current: 5 A
Switch-on voltage: 27 V
Switch-off difference: 0,5 V
Operating temperature: -25 °C to +65 °C
Inverse polarity protection and short-circuit-proof. Protection rating



Load compensation device "Plus"

8ES 008 124-001

Technical details

Rated voltage: 24 V
Compensation current: 8 A
Switch-on voltage: 27 V
Switch-off difference: 0,5 V
Operating temperature: -25 °C to +65 °C
Inverse polarity protection and short-circuit-proof. Protection rating

Hella trailer connection device

Allows the connection of 12 V trailers to towing vehicles with 24 V operating voltage without having to use a separate load compensation device. Further product advantages: low installation and cabling expenditure; the existing C2 control of the 24 V flasher unit monitors the 12 V trailer at the same time; the device can be installed both on the towing vehicle or between the two vehicles ("suspended"); suitable for universal use (suitable for all commercial vehicles with 24 V operating voltage).

5DS 008 125-011



Plugs and sockets



Socket, 7-pin
with 7 screw connections

8JB 003 833-001



Plug, 7-pin
with 7 screw connections

8JA 003 831-001



Socket
with 7 screw connections

8JB 003 834-001



Plug
with 7 screw connections

8JA 003 832-001



Short adapter
Short adapter from 15-pin socket (DIN ISO 12098)
to 2 x 7-pin sockets
(DIN ISO 1185 "N" type + DIN ISO 3731 "S" type)

8JA 005 952-061



Helical connecting cables for semitrailer towing vehicles and articulated trucks

Interior diameter of the helical cable:
90mm. With plastic plugs.

N type: acc. to DIN ISO 1185 **8KA 004 797-041**

S type: acc. to DIN ISO 3731 **8KA 004 797-051**

Interior diameter of the helical cable:
25 mm. With metal plugs and anti-kink feature.

N type: acc. to DIN ISO 1185 **8KA 004 797-101**

S type: acc. to DIN ISO 3731 **8KA 004 797-111**



Keeping an eye on safety – *Hella mirrors for safe and effortless manoeuvring*

Hella supplies a comprehensive range of vehicle-specific mirrors for trucks. This puts us in a position to offer a wide range for vehicles from all the major European truck manufacturers: e.g. for **Mercedes-Benz, Volvo, Scania, DAF, Iveco and VW.**

But a wide range with good cover is not enough: we place special value on quality, which increases active safety in road traffic. Hella mirrors have to meet the toughest quality requirements during both development and production. The mirrors are tested under extreme conditions to their load limits. So we make sure only high-quality materials are used and can withstand the tough requirements of the day-to-day freight business.





Hella back-up alarm – an acoustic signalling system in reverse gear

Back-up alarms are activated when the reverse gear is engaged. An acoustic signal sends a warning to anyone standing behind the vehicle. Thanks to their multiple attachment possibilities, back-up alarms are used on trucks, buses, agricultural and construction machinery, fork-lift trucks and mobile working platforms.

The product advantages at a glance:

- The housings sealed with epoxy resin provide protection against humidity, soiling and vibration. Making it possible for them to be cleaned using a high-pressure jet cleaner.
- Hella supplies a comprehensive range of back-up alarms with fixed sound pressure levels between 87 and 112 dB (A).
- Hella supplies back-up alarms that increase their sound pressure level automatically to at least 5 dB (A) above the environment noise level.
- Hella back-up alarms are protected against inverse polarity and voltage peaks.
- All devices can be used in a temperature range of $-40\text{ }^{\circ}\text{C}$ to $+85\text{ }^{\circ}\text{C}$.
- All back-up alarms are built to Hella quality standards



Hella KG Hueck & Co.
Rixbecker Straße 75
59552 Lippstadt/Germany
Tel.: +49 (0) 29 41/38-0
Fax: +49 (0) 29 41/38-71 33
Internet: www.hella.com



*Ideas today for
the cars of tomorrow*